

HYUNDAI
POWER PRODUCTS

PETROL REAPER

HFT200-1

ORIGINAL INSTRUCTIONS



GENUINE PRODUCT OF
HYUNDAI CORPORATION

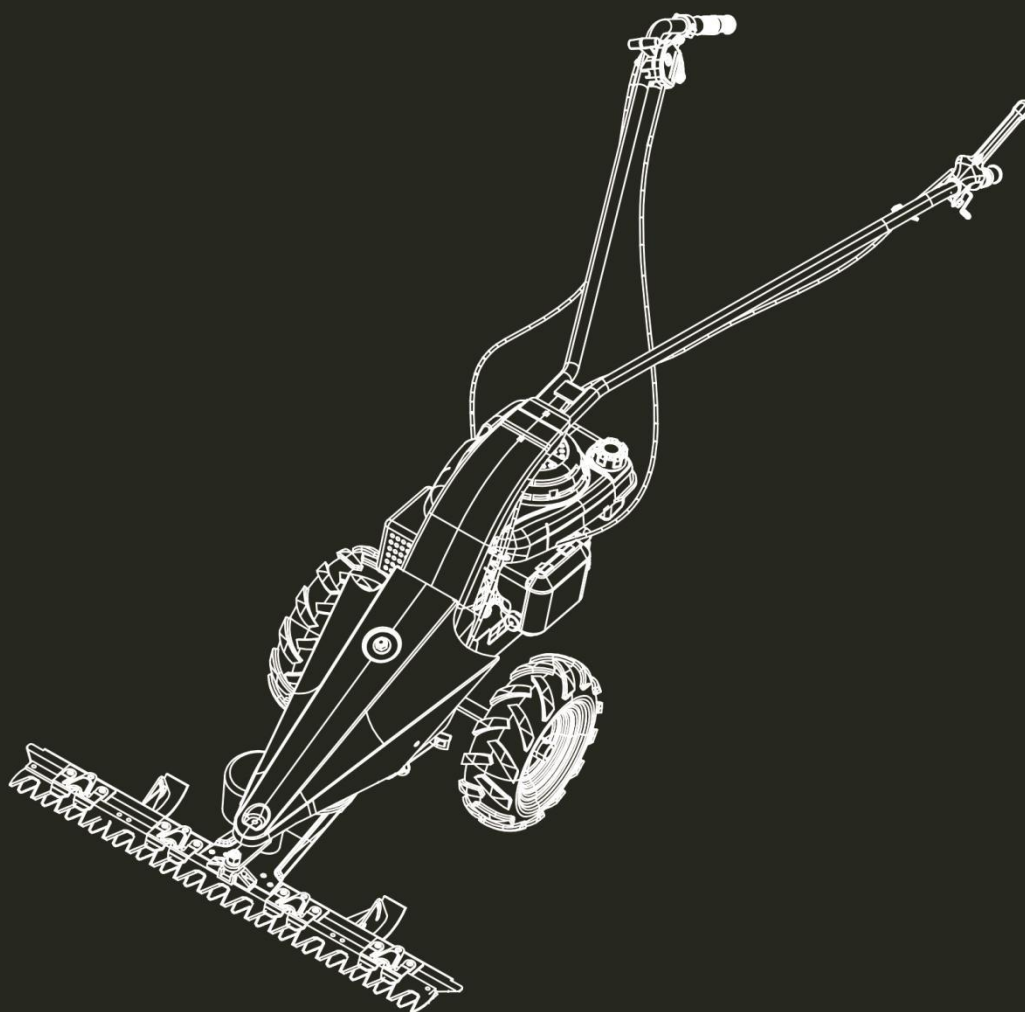

WARNING: Read thoroughly the instruction manual before use.

CONTENTS

1. PROPER USE.....	3
2. GENERAL SAFETY INSTRUCTIONS.....	3
3. RAYNAUD'S SYNDROME (WHITE-FINGER SYNDROME).....	4
4. PRODUCT-SPECIFIC SAFETY INFORMATION.....	4
5. GENERAL INSTRUCTION.....	5
6. PREPARATORY ACTIONS.....	5
7. WARNING SYMBOLS.....	6
8. PRODUCT DESCRIPTION.....	7
9. TECHNICAL DATA.....	8
10. ASSEMBLY.....	8
11. USING FOR THE FIRST TIME.....	11
12. OPERATION.....	15
13. CLEANING AND MAINTENANCE.....	17
14. STORAGE AND TRANSPORT.....	21
15. DISPOSAL.....	21
16. TROUBLESHOOT.....	21
17. DECLARATION OF CONFORMITY.....	23
18. WARRANTY.....	24
19. PRODUCT FAILURE.....	25
20. WARRANTY EXCLUSIONS.....	26

IMPORTANT: Please read and save these instructions. Read through this owner's manual carefully before using product. Protect yourself and others by observing all safety information, warnings and cautions. Failure to comply with instructions could result in personal injury and/or damage to product or property. Please retain instructions for future reference.

1. PROPER USE

The product is intended for cutting grass areas in private and hobby gardens.

The product may not be used for commercial purposes.

The product may not be used in potentially explosive environments.

The product may not be used in environments in which a fire hazard exists.

The product must be operated according to the manufacturer's specifications in the instructions for use.

Any improper use or any activities on the product not described in these instructions for use are considered inadmissible misuse and outside of the manufacturer's legal liability

2. GENERAL SAFETY INSTRUCTIONS

- The machine shall always be used in accordance with the manufacturer's instructions laid down in the instructions handbook
- The engine shall be stopped when changing blades
- Start up the tool under normal conditions and when an emergency device is used
- when start the engine, the operator shall not lift the machine,
- The machine shall only be brought into an inclined position when the cutting blade is turned to the side opposite to the operator
- Before transport of the machine, the engine has to be turned off and the cutting blade has to have stopped moving, and that whilst moving the machine outside of the workplace, the cutting blade has to be disengaged from the power source
- Only cutting blades approved by the manufacturer shall be fitted to the machine according to the manufacturer's instructions.
- WARNING -Reduce the risk of injury by reading the instructions for use.
- WARNING! Read all safety information and instructions! Failure to observe the safety information and instructions can cause electric shock, fire and/or serious injury.
- Should you pass the product on, ensure that it is accompanied by the instructions for use. Keep all instructions for use and safety instructions for future reference.
- Observe all safety instructions! If you do not observe the safety instructions you will endanger yourself and others.
- Keep the work area clean and well-illuminated. Untidiness and unlit working areas can lead to accidents.
- Wear personal protective equipment and always use safety goggles. Wearing personal protective equipment such as hearing protection reduces the risk of injury.
- Keep children and other persons away when using the product. Distractions may cause you to lose control of the product.
- All parts of the product must be correctly installed to ensure faultless operation.
- Young people under 16 years of age and users who are not sufficiently acquainted with its operation must not use the product.
- The product may be used only when in a faultless condition. If the product or a part of it is defective, it must be repaired by Dealer's Service.
- The surroundings must be free of highly-flammable or explosive materials.

- Do not operate the product unless the protection devices are fitted.
- Take care at the cutting tool – maintain an adequate safe distance.
- Exercise caution with tools that run-on. Before commencing work on these tools, wait until they have come to a complete standstill!
- Danger of poisoning due to exhaust fumes! Do not start the motor or use the product in enclosed spaces.
- Never leave the product unattended with the motor running.
- Check the fuel system for leaks or defective parts on a regular basis.
- Always switch off the motor when transporting or refueling.
- Carefully remove overflowing fuel without delay.
- Conversions, unauthorized modifications and the use of non-approved parts are prohibited.
- Always heed the applicable national and international safety, health and labour regulations.
- Work with caution and only if you are physically fit: Working under the effects of fatigue, illness, alcohol, medication and drugs is irresponsible.
- Only the maintenance work and trouble shooting activities described here may be carried out. All other work must be carried out by Dealer's Service.
- Use only genuine spare parts. Only these spare parts are designed and suitable for the product. The use of other spare parts not only invalidates the warranty, it also presents a danger to yourself and your environment.
- Limit the time of operation.

3. RAYNAUD'S SYNDROME (WHITE-FINGER SYNDROME)

The frequent use of vibrating devices can damage the nerves of persons whose blood flow is impaired (e.g. smokers, diabetics). Fingers, hands, wrists and/or arms in particular show some or all of the following symptoms: Pain, prickling, twinges, deadening of limbs, pale skin.

If you notice anything unusual, stop working immediately and consult a physician.

You can substantially reduce the risks if you adhere to the following instructions:

- Keep your body and particularly your hands warm in cold weather. Working with cold hands is the main cause!
- Take regular breaks and move your hands. This encourages circulation.

Ensure that the product vibrates as little as possible through regular maintenance and tight parts on the product.

4. PRODUCT-SPECIFIC SAFETY INFORMATION



CAUTION! Product damage!

The product is supplied without motor oil.

Make sure it is filled with motor oil before using for the first time.

The oil level must be checked and topped up/refilled each time before using the motor.

Operating the motor with insufficient oil will damage the motor.

Dirty oil or two-stroke motor oil reduces the service life of the motor. The motor oil must be changed after the first five operating hours.

Use the specified motor oil.



CAUTION! Product damage!

The product is supplied without gearbox oil.

Make sure it is filled with gearbox oil before using for the first time. Operating the gearbox with insufficient oil will damage the gearbox.

Contaminated gearbox oil will reduce the service life of the gearbox. Use the specified gearbox oil.

5. GENERAL INSTRUCTIONS

- Carefully read the instructions for use. Familiarize yourself with the operating elements and the correct use of the product.
- Never allow children or other persons not acquainted with the operating instructions to use the product. Local regulations may specify the minimum age of the user.
- Never work when persons, especially children and animals, are close by.
- Remember that the operator or the user is responsible for accidents involving other persons or damage to their property.

6. PREPARATORY ACTIONS

- Always work wearing sturdy shoes and long trousers. Do not operate the product barefoot or wearing light shoes.
- Make a thorough check of the terrain on which the product is to be used and remove any objects that could be flung out by the product.
- Replace damaged exhaust silencers.
- Always visually examine the cutting tool before use to make sure it is not worn or damaged.

For handling fuels

- **WARNING** - Petrol is highly inflammable:
 - Only store petrol in containers fit for the purpose.
 - Only refuel outdoors and do not smoke during the refueling process.
 - Petrol must be topped up before the motor is started.
 - Do not open the petrol cap or refill with petrol while the motor is running or the motor is hot.
 - Never attempt to start the motor if petrol has been split.
 - Instead, move the product away from the contaminated area. Avoid all attempts to start the motor until the petrol vapors have evaporated.
 - For safety reasons the petrol tank and petrol cap are to be replaced on a regular basis.

If used improperly, operating media (including fuels) endanger the environment:

- Take care when filling with operating media. Operating media must not run into the soil or into the sewer system.
- Operating media residues must be disposed of properly. Never dispose of them with household waste.
- Observe the applicable national regulations for the handling of the respective operating media.
- Fuels have a limited shelf-life. Buy only the quantity of fuel you will use up within the next few months.

Handling









- Do not run the motor in enclosed spaces in which dangerous carbon monoxide can collect.
- Only work in daylight or with adequate lighting.
- Always ensure good stability on slopes.
- Only operate the product at walking pace.
- Products on wheels: Always work across slopes, never up or down the slope.
- Be especially vigilant when changing direction on slopes.
- Never work on extremely steep slopes.
- Be particularly vigilant when turning the product round or pulling it towards you.
- Do not modify the motor's basic settings and do not over-rev it.
- Carefully start the motor in accordance with the instructions and ensure there is an adequate distance from your feet to the tool(s).
- Never place your hands or feet on or under rotating parts.
- Always keep your hands and feet well away from the area of the cutting tool

- Never lift or carry a product while the motor is running.
- The motor must be switched off:
 - whenever you leave the product.
 - before refueling.
- The throttle valve must be closed when the motor runs on. If the product is fitted with a petrol valve, this must be closed when work is complete.

MAINTENANCE AND STORAGE

- Always make sure that all nuts, bolts and screws are firmly tightened. This will ensure that the product is in a safe working condition.
- While petrol is in the tank, never store the product in a building in which petrol vapours may come into contact with naked flames or sparks or can be easily ignited.
- Allow the motor to cool down before storing product in enclosed spaces.
- To avoid the risk of fire keep the motor and exhaust away from vegetable matter and leaking grease (oil).
- For safety reasons always replace worn or damaged parts.
- Should the tank need draining, do this outdoors.

7. WARNING SYMBOLS:

	<p>Wear appropriate hearing protection while working with the product! Wearing hearing protection reduces the risk of injury. Wear goggles while working with the product! Wearing goggles reduces the risk of injury.</p>
	<p>Wear safety shoes while you are working with the product! Wearing safety shoes reduces the risk of injury</p>
	<p>Wear tight fitting clothing while working with the product. Loose fitting clothing can get pulled in while working with the product</p>
	<p>Wear safety gloves while working with the product! Wearing safety gloves reduces the risk of injury</p>
	<p>Hot surface, keep a distance away!</p>
	<p>Don't touch the cutting tool! Risk of injuries</p>
	<p>Caution! Risk of projections - keep bystanders away!</p>
	<p>Guaranteed sound power level.</p>

8. PRODUCT DESCRIPTION

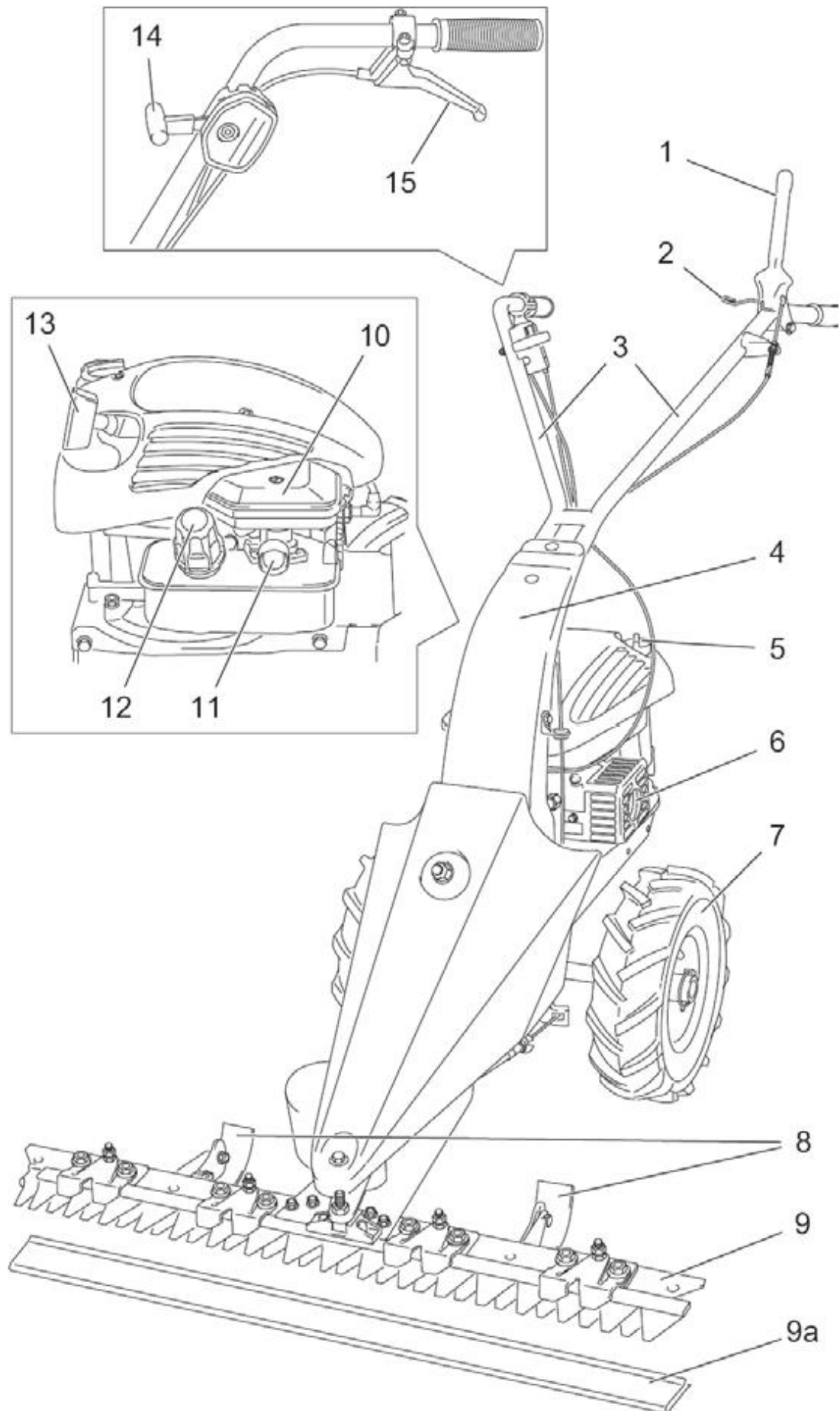

- | | |
|---------------------------------------|--|
| 1) Coupling handle (for cutting tool) | 9) Cutting tool |
| 2) Latch | 9a) Cutting tool guard |
| 3) Steering | 10) Air filter unit |
| 4) Arm housing | 11) Fuel pump (without pump on this model) |
| 5) Motor oil filling screw | 12) Tank cover (for fuel) |
| 6) Exhaust with protective grille | 13) Pull-starter |
| 7) Wheel | 14) Throttle |
| 8) Ground sliders | 15) Coupling handle (for wheel drive) |

Supplied as standard

- Field mower
- Cutting tool
- Instructions for use
- Sliding block
- Steering
- Cutting tool guard
- Arm housing
- Linch pin (2 x)
- Wheel (2 x)

Note: If a part is missing or damaged, please contact the vendor.

9. TECHNICAL DATA:

Engine Power	3,5kW
Displacement	196cm ³
Engine max speed	3000/min
Cutting width	870mm
Weight	59kg
Sound pressure level	LpA= 90,4dB(A) K=3dB
Sound power level	LwA=105,4dB(A) K=3dB
Guarantee sound power level	LwA= 108dB(A)
Vibration	32,5m/s ² ;K=1.5 m/s ²

10. ASSEMBLY

1) Mounting the wheels

 **WARNING! Risk of injury!** Make sure that the linch pin closes fully.

 **CAUTION! Product damage!** Pay attention to the running direction of the wheel. The profile of the wheels must point forward in travel direction

 **CAUTION! Product damage!** Always make sure that the tyres have the correct air pressure.

- Push the protective cap (17) onto the drive shaft (16).
- Push the wheel (7) with the valve facing outwards onto the drive shaft (16). If necessary, first remove the linch pin (18) from the drive shaft (16).
- Two holes which in the hub of wheel(7) and the drive shaft must be in alignment, then Insert the linch pin(18) through the holes "
- Close the linch pin (18).
- Repeat the procedure on the other side

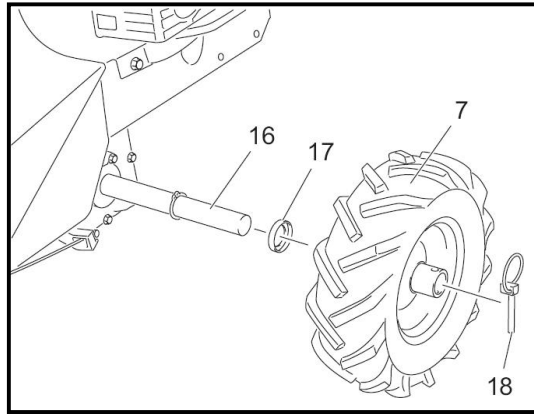

2) Mounting the arm housing

- Unscrew the screws (19) with the circlip and the washer on both sides of the product.
- Place the arm housing (4) onto the product and screw down to the product again with the screws (19).

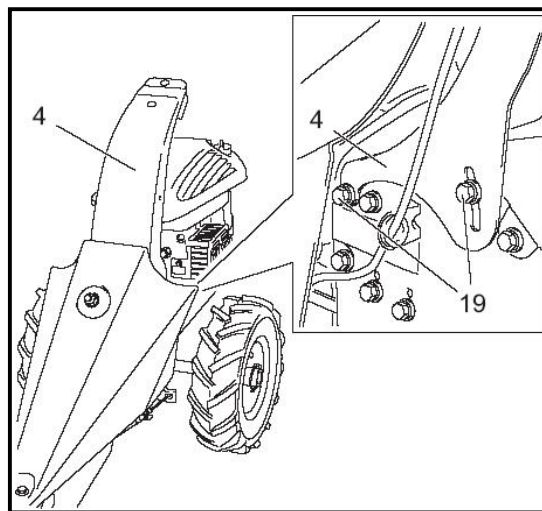

3) Mounting the steering

⚠ CAUTION! Product damage! Pay attention to the routing of the Bowden cables. The Bowden cables may neither be routed in too small a radius nor may they be crushed.

- Loosen the self-locking nut (20) with the circlip and the washer from the round-head screw with square neck (21).
- Push the steering (3) onto the round-head screw with square neck (21).
- Screw the self-locking nut (20) with the circlip and the washer onto the round-head screw with square neck (21) and tighten it.

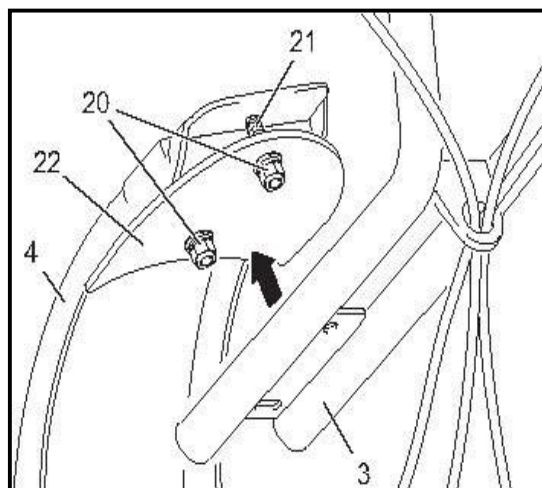

Note: Make sure that the vibration damper (22) between the arm housing (4) and the steering (3) is installed.

4) Mounting the Bowden cable guide

⚠ CAUTION! Product damage! Pay attention to the routing of the Bowden cables. The Bowden cables may neither be routed in too small a radius nor may they be crushed!

- Loosen the self-locking nut (28) with the circlip and the washer from the screw (29).
- Push the screw (29) with the washer through the hole in the bracket (30) and the arm housing (4).
- Screw the self-locking nut (28) with the circlip and the washer onto the screw (29) and tighten it.

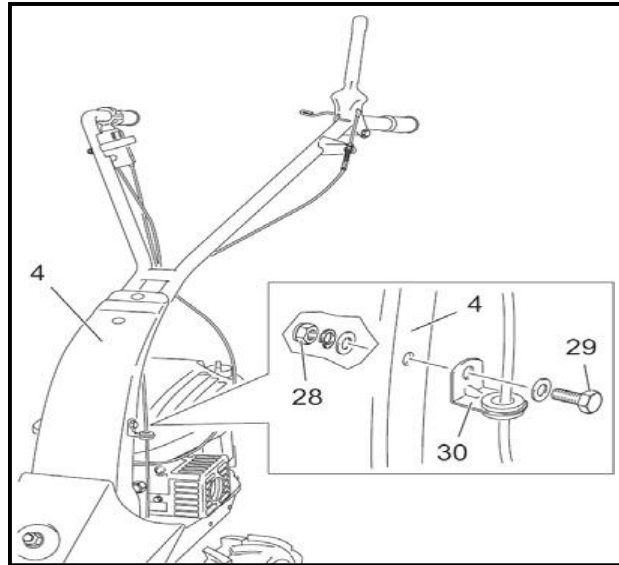

5) Mounting the cutter

⚠ WARNING! Risk of injury!

Make sure that the cutting tool guard (9a) is installed on the cutter (9)

- Loosen the self-locking nut (23) with the circlip and the washer from the screw (24) with the washer.
- Place the base plate (25) onto the cutter (9).
- Direct the sliding block (26) into the guide (27) on the cutter (9).
- Align the cutter (9) and the base plate (25) to one another.
- Direct the screw (24) with the washer from below through the cutter (9) and the base plate (25).
- Screw the self-locking nut (23) with the circlip and the washer onto the screw (24) and tighten it.
- Replacing of the cutter by operating in reverse order above

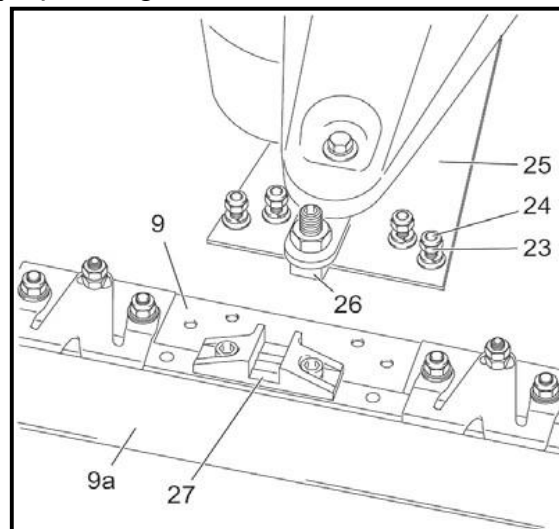

11. USING FOR THE FIRST TIME PRODUCT CONTROLS

WARNING! Risk of injury!

Before performing any adjustment work, always switch the product off and remove the spark plug connector.

1) **Setting the steering height**

- Slightly loosen the screws (19) with the circlip and the washer on both sides of the arm housing (4).
- Set the desired steering height.
- Tighten the screws (19) with the circlip and washer again.

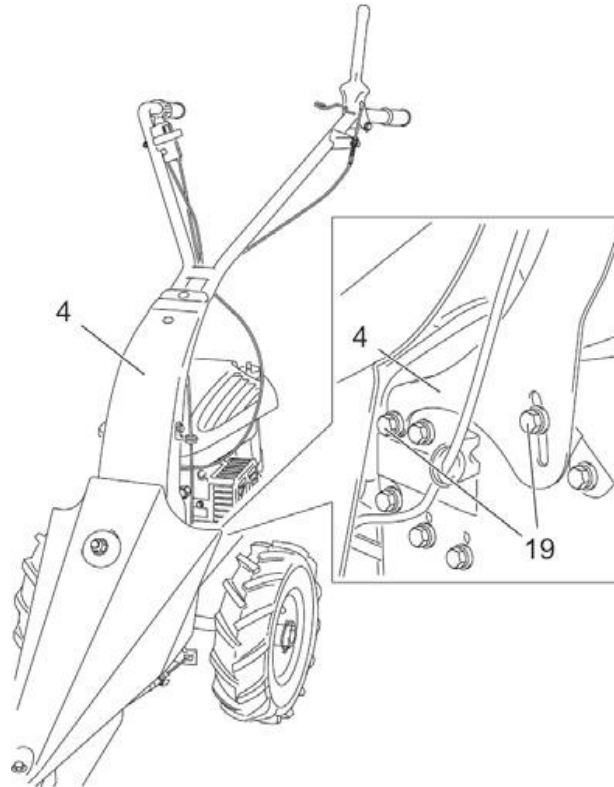

2) **Adjust the sliding block**

WARNING! Risk of injury!

Make sure that the cutting tool guard (9a) is installed on the cutter (9)

CAUTION! Product damage!

The sliding block (26) must always be correctly adjusted. An incorrect adjustment can result in the cutter jumping out of the guide (27) or damage being caused to the cutting tool (9)

- Secure the adjustment screw (31) against turning with a suitable tool.\
- Loosen the nut (32) with a suitable tool.
- Change the height of the adjustment screw by turning.
- Protect the adjustment screw (31) against turning with a suitable tool and tighten the nut again using an appropriate tool.

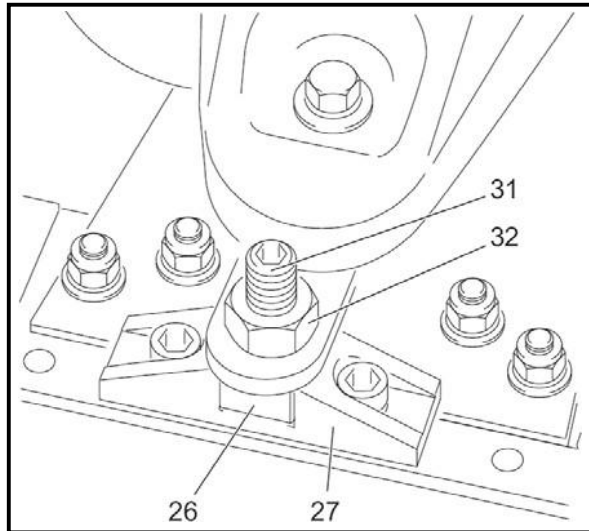

3) Adjusting the cutting height

⚠ WARNING! Risk of injury!



Never set the cutting height too low. The ground sliders (8) must still touch the ground.

The cutter (9) could become caught in the ground and cause the product to suddenly come to a halt

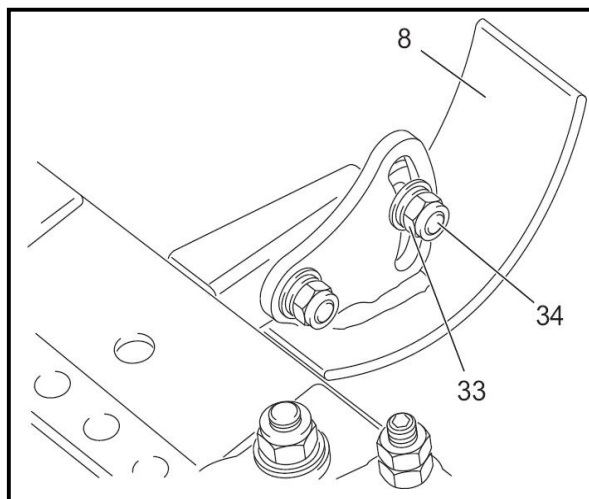
- Slightly loosen the self-locking nut (33) with the circlip and the washer from the screw (34).
- Adjust the height of the ground sliders (8).
- Re-tighten the self-locking nut (33) with the washer and the screw (34).



4) Throttle

- Throttle in (14) position  = Motor off
- Throttle in (14) position  = minimum motor speed
- Throttle in (14) position  = maximum motor speed

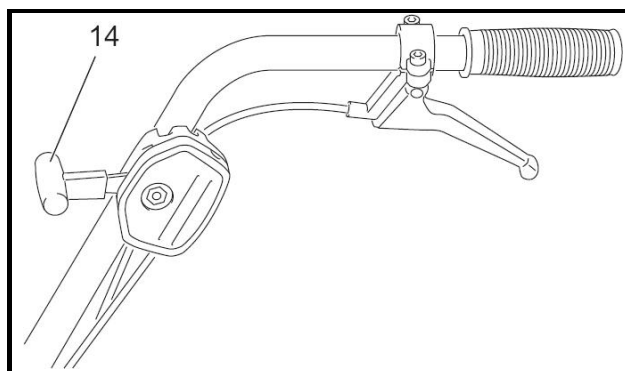

5) Coupling handle for wheel drive

When the coupling handle is released (15), the cable pull must be completely relieved.

- Coupling handle released (15) = product standstill
- Coupling handle (15) pulled = Wheels (7) begin to move and the product starts running.

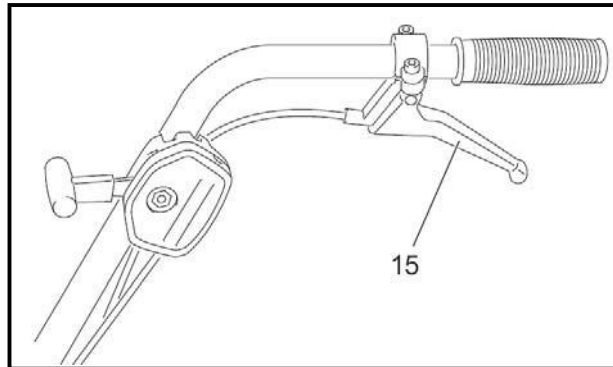

6) Coupling handle for cutting tool

When the coupling handle (1) is released, the cutting tool (9) must not move; When the coupling handle is pressed, the cutting tool (9) must start to move. The coupling handle (1) can be locked using the latch (2)

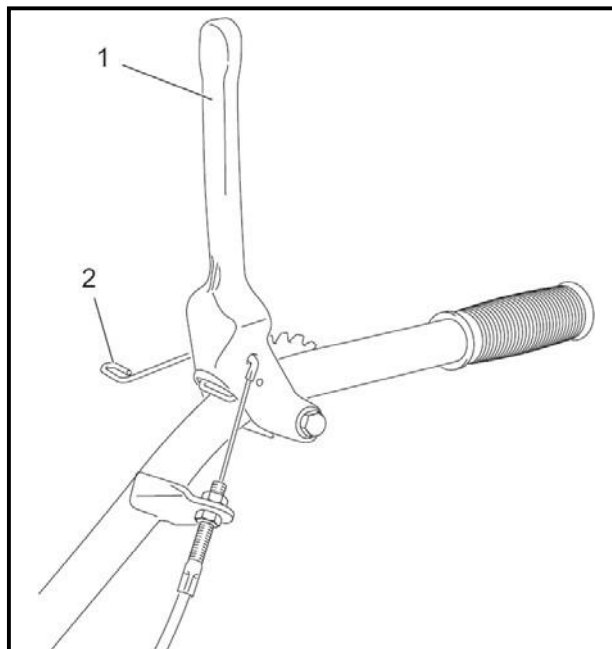

7) Filling with fuel



DANGER! Risk of injury! Petrol is highly inflammable!

- Before refuelling, switch off the motor and let it cool down.
- Closely observe all safety information for handling fuel.

Note: Use only appropriate fuel.

- 1) Switch off the motor.
- 2) Disconnect the spark plug.
- 3) Open and remove the tank cover (12).
- 4) Carefully top up the fuel. Do not spill!
- 5) Check the seal in the tank cover for damage and clean if necessary.
- 6) Replace a damaged seal immediately!
- 7) Re-tighten the tank cover (12) by hand

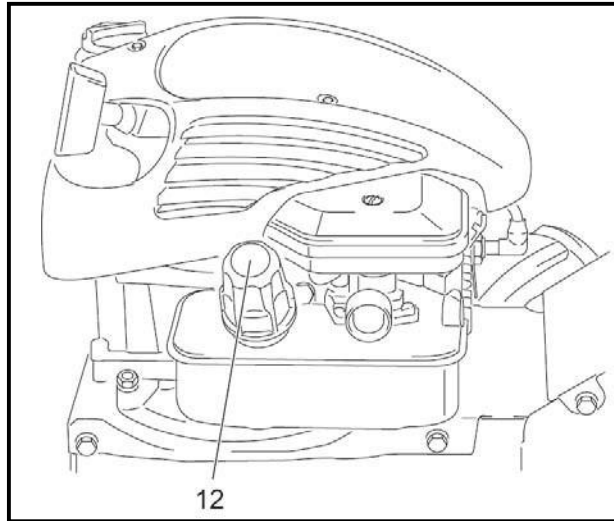

8) Filling with motor oil

CAUTION! Product damage!

The product is supplied without motor oil. Make sure it is filled with motor oil before using for the first time. The motor oil must be changed after the first five operating hours. The oil level must be checked and topped up refilled each time before using the motor

- 1) Switch off the motor.
- 2) Disconnect the spark plug.
- 3) Unscrew and remove the motor oil filling plug (5).
- 4) Carefully top up the motor oil. Do not spill!
- 5) Check the seal in the motor oil filling plug (5) for damage and clean if necessary.
- 6) Replace a damaged seal immediately!
- 7) Re-tighten the motor oil filling plug (5) by hand.
- 8) Check motor oil level.

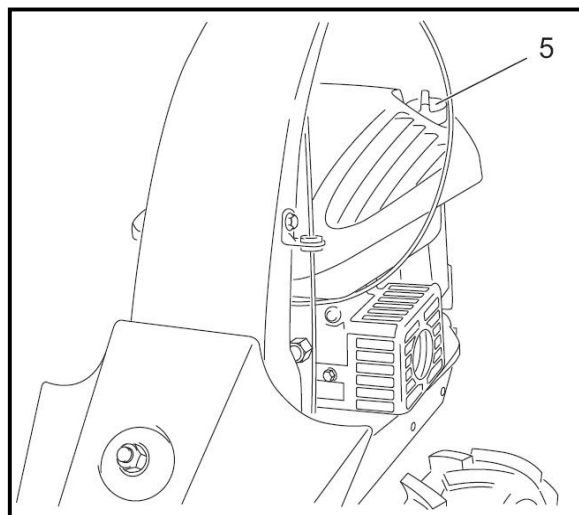

9) Filling with gearbox oil

CAUTION! Product damage!

The product is supplied without gearbox oil.

Make sure it is filled with gearbox oil before using for the first time. Operating the gearbox with insufficient oil will damage the gearbox.

Contaminated gearbox oil will reduce the service life of the gearbox. Use the specified gearbox oil.

- 1) Switch off the motor.
- 2) Disconnect the spark plug.
- 3) Unscrew and remove the gearbox oil filling plug (36) using a suitable tool.
- 4) Carefully top up the gearbox oil. Do not spill!
- 5) Re-tighten the gearbox oil filling plug (36)

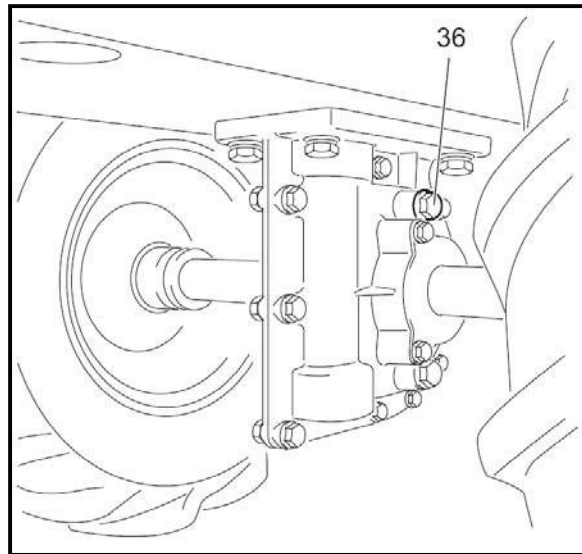

12. OPERATION

Check before starting!



WARNING! Risk of injury!

The product must only be put into operation if no defects are found. Ensure that any defective parts are replaced before the product is used again



CAUTION! Product damage!

The product is supplied without motor oil.

Make sure it is filled with motor oil before using for the first time.

The oil level must be checked and topped up refilled each time before using the motor.

Operating the motor with insufficient oil will damage the motor.

Dirty oil or two-stroke motor oil reduces the service life of the motor. The motor oil must be changed after the first five operating hours.



Use the specified motor oil.

CAUTION ! Product damage!

The product is supplied without gearbox oil.

Make sure it is filled with gearbox oil before using for the first time. Operating the gearbox with insufficient oil will damage the gearbox.

Contaminated gearbox oil will reduce the service life of the gearbox. Use the specified gearbox oil

Check the safe condition of the product:

- Check whether there is any leakage.
- Check whether there are any visible defects.
- Check whether all parts of the product are firmly attached.
- Check that the safety devices are in faultless condition

1) Starting the engine



DANGER! Danger of fire!

Spilled fuel can set the product on fire.

Carefully wipe up any spilled fuel up before starting.

Start the product a minimum of nine meters away from where you filled it.

CAUTION! Product damage!

The motor's durability and operating safety hinges on its run-in time. Always allow a cold motor to warm up for a few minutes, do not demand full power immediately. During the first 20 hours of operation (run-in time), do not push the motor to its performance limit.

- Check motor oil level.
- Set the throttle to position 
- Slowly pull the pull-starter (13) straight until you feel a resistance.
- Let the pull-starter (13) run in again.
- Keep pulling the pull-starter (13) until the motor starts.

If the motor does not start, repeat the starting procedure. After starting the motor, set the required motor speed using the throttle (14)

Note: Pull the pull-starter max. 50 cm out and let it run back in slowly by hand.

2) Switching off the motor

WARNING! Risk of injury!

Always switch off the product when not in use for short periods.

Set the throttle (14) to position 

3) Mowing

WARNING! Risk of injury!

Before beginning work, check the terrain and remove all objects that may be flung out by the product.

WARNING! Risk of injury!

Never let go of the steering while working.

WARNING! Risk of injury!

If there is a risk of slipping on slopes, the product is to be held by a second person using a bar or a rope. The second person must stand above the product and maintain an adequate distance from the cutting tool.

Always work across slopes, never upwards or downwards. Be especially vigilant when changing direction.

WARNING! Risk of injury!

Do not clean the cutting tool while the engine is running. Switch off the motor and remove the spark plug connector. Always use aids, e.g. a piece of wood for removing jammed objects,

- Start the motor.
- Use the throttle to set the motor to the required speed.
- Press the coupling handle (1) and keep it pressed.
- Pull the coupling handle (15) and keep it pulled.
- Switch off the motor after completing the work

13. CLEANING AND MAINTENANCE



WARNING! Risk of injury!

Changing the blades according to the opposite steps of mounting the cutter.



WARNING! Risk of injury!

Before any maintenance or cleaning work:

- Switch off motor.
- Allow the product to cool down.
- Disconnect the spark plug



WARNING! Risk of injury!

Perform only the maintenance work described here yourself.

Any other work, especially motor maintenance and repairs must be performed by a trained professional. Improper work can cause product damage and hence physical injury

1) Cleaning and maintenance at a glance

Before each use

What	How
Check screw connections are tight.	Hand-tighten the screw connections using the appropriate tool
Check motor oil level	Checking the motor oil level
Check tyre pressure	Air pressure gauge
Check cable of the pull-starter for damage	Visual inspection
Check the blades	Visual inspection

After each use

What	How
Clean the product	Cleaning the product
Lubricate the cutting too	Draining the motor oil

After the first five operating hours

What	How
Change the motor oil.	Draining the motor oil

Every 25 operating hours or every 3 months

What	How
Replace the air filter	Cleaning/replacing the air filter
Remove grass and dirt from rotating parts	Using a brush or another suitable blunt object
Clean covers	Wipe down with a slightly damp cloth

Every 100 operating hours or every 12 months

What	How
Clean/replace the spark plug	Cleaning/replacing the spark plug
Change the gearbox/motor oil	Draining the motor oil /Changing the gearbox oil

2) Cleaning the product



WARNING! Risk of injury!

Clean the cutting tool carefully. The cutting tool may still move even though the product is switched off.

Careful handling and regular cleaning ensure that the product remains functional and efficient for a long time.

Clean the product immediately after each use. Dried-on grass is extremely hard and difficult to remove.

- Brush off coarse dirt.
- Wipe down the product with a slightly damp cloth.
- Never spray the product with water or expose it to water.
- Never use cleaning agents or solvents.
- Keep ventilation slots clean and free of dust

3) Checking the motor oil level



CAUTION! Product damage!

The product is supplied without motor oil.

Make sure it is filled with motor oil before using for the first time.

The oil level must be checked and topped up refilled each time before using the motor.

Operating the motor with insufficient oil will damage the motor.

Dirty oil or two-stroke motor oil reduces the service life of the motor. The motor oil must be changed after the first five operating hours. Use the specified motor oil.

- Switch off the motor.
- Disconnect the spark plug.
- Unscrew and remove the motor oil filling plug (5).
The oil dipstick is fastened to the motor oil filling plug (5).
- Wipe the dipstick clean using a cloth.
- Insert the motor oil filling plug (5) with the dipstick again and screw in.
- Unscrew the motor oil filling plug (5) again and pull it out.
- Check the oil level.

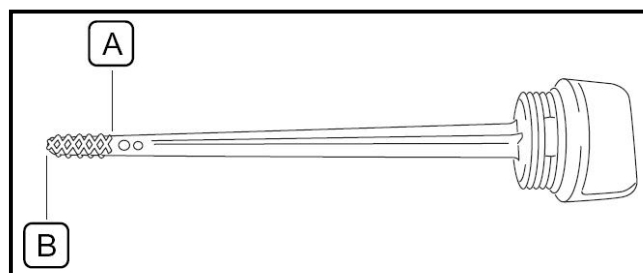

The oil level should be at the top marking (A) of the oil dipstick. If the oil level is below the bottom limit mark (B) of the oil dipstick, slowly top up with oil until the oil level reaches the top mark on the oil dipstick. Do not overfill the product.

- Check the seal in the motor oil filling plug (5) for damage and clean if necessary.
- Replace a damaged seal immediately!
- Insert the motor oil filling plug (5) again and tighten it by hand.

4) Draining the motor oil

- Switch off the motor.
- Disconnect the spark plug.
- Unscrew and remove the motor oil filling plug (5).

- Hold a collecting container below the motor oil drain plug (35).
- Unscrew and remove the motor oil drain plug (35) using a suitable tool.
- Allow the motor oil to drain completely.
- Insert the motor oil drain plug (35) and tighten using a suitable tool.
- Top up motor oil before using again.

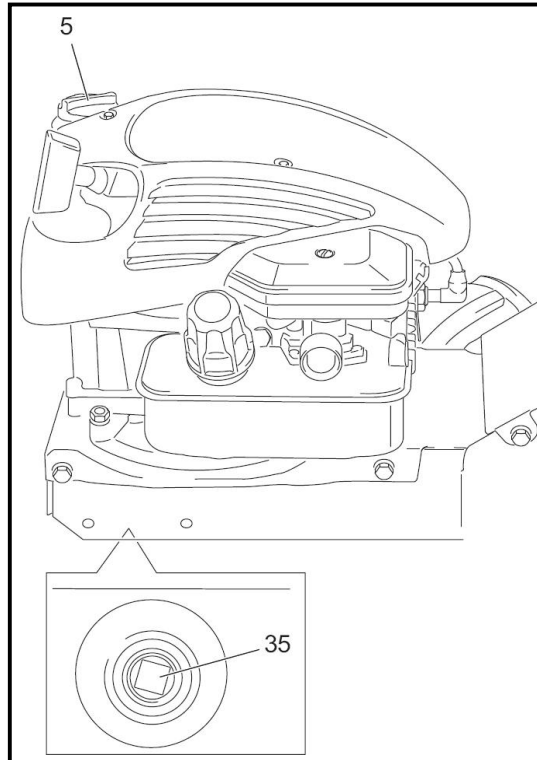

5) Draining the gearbox oil

- Switch off the motor.
- Disconnect the spark plug.
- Hold a collecting container below the gearbox oil drain plug (37).
- Unscrew and remove the gearbox oil filling plug (36) and gearbox oil drain plug (37) using a suitable tool.
- Allow the gearbox oil to drain completely.
- Insert the gearbox oil drain plug (37) and tighten using a suitable tool.
- Top up gearbox oil before using again

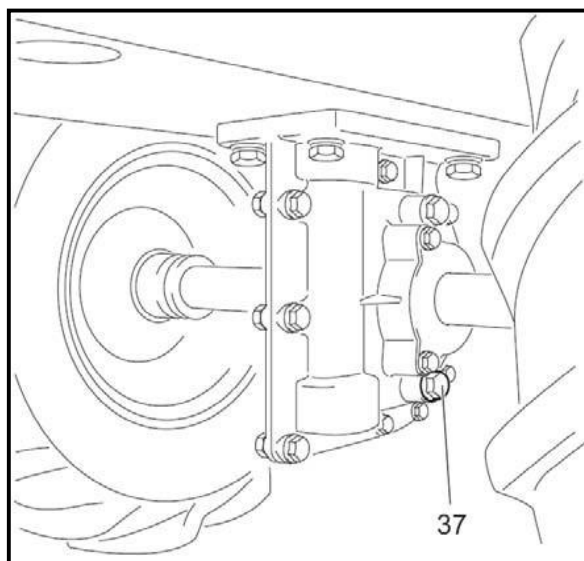

6) Cleaning/replacing the air filter

⚠ CAUTION! Product damage!

The product must never be operated without the air filter, as this can cause damage to the motor. The air filter must be replaced if it is damaged or badly contaminated.

- Switch off the motor.
- Disconnect the spark plug.
- Remove the bolts and air filter cover. Be careful to prevent dirt and debris from falling into the air filter base opening.
- Remove the foam element or paper element.
- Check, clean or replace the damaged air cleaner parts.
- Reinstall the air filter parts, then bolt and screw down it.

⚠ WARNING! Never clean the air filter element with gasoline or low flash-point detergents, or explosion may happen.

⚠ CAUTION! Clean the foam filter with soapy water, blow the paper element with compressed air or lightly tap off dust and never dry to brush.

7) Cleaning/replacing the spark plug

⚠ CAUTION! Product damage!

To clean the spark plug, use only wire brushes with brass bristles. Bristles of any other material will damage the electrode!

⚠ CAUTION! Product damage! Fit the spark plug only when motor is cold

- Switch off the motor.
- Pull off the spark plug connector (40).
- Unscrew the spark plug (41).
- Check the electrode for discoloration.
Standard colour: light brown
- Check the electrode distance.
Correct distance: 0.7 mm to 0.8 mm

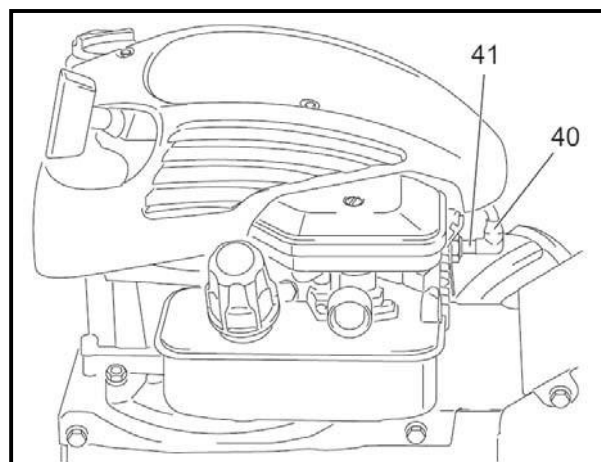

Cleaning the spark plug

- Remove rust from the electrode with a wire brush.

Replacing the spark plug

- Insert a cleaned or new spark plug and tighten by hand.
- Tighten hand-tightened spark plug by approx. quarter of a rotation using the spark plug

wrench. Do not tighten spark plug too tight, otherwise the threads will be damaged.

- Replace the spark plug connector (40) firmly on the spark plug.

8) Changing the gearbox oil

- Draining the gearbox oil
- Filling with gearbox oil

14. STORAGE AND TRANSPORT

 **WARNING! Risk of injury!**

The motor must be switched off during maintenance and cleaning work and when transporting without its own drive!

Storage

- Let the product cool before storing.
- Store the product in a dry, well-ventilated place.

Longer downtimes (3 months or longer)

Always remove fuel from the product before storing for longer periods.

- Empty the tank.
- Start the motor and let it run until the motor switches off by itself.

Transportation in a vehicle

- Allow the product to cool down.
- Empty the tank.
- Secure the product to stop it slipping and tipping over.

15. DISPOSAL

Disposing of the product

 **CAUTION! Environmental damage, fire hazard!**

Avoid damage caused by leaking fuel, motor oil or gearbox oil: Remove all operating media before disposing of the product.

Do not dispose of the product with the household waste! Proper disposal is mandatory.

Information can be obtained from the responsible waste disposal facility.

Disposing of packaging

The packaging consists of cardboard and appropriately marked films, which can be recycled.

Take these materials to a recycling facility.



16. TROUBLESHOOTING

 **WARNING! Risk of injury!**

Improper repairs can result in the product functioning unsafely. This endangers yourself and your environment.

Malfunctions are often caused by minor faults. You can easily remedy most of these yourself. Please consult the following table before contacting the dealer. You will save yourself a lot of trouble and possibly money too.

Fault/malfunction	Cause	Remedy
Motor does not start	Tank empty?	Filling with fuel
	Excess fuel in the combustion chamber?	Screw out the spark plug, dry off the electrode and start with throttle fully open

	Incorrect fuel?	Drain tank and fill up with the correct fuel
	Spark plug connector not firmly attached?	Push the connector firmly onto the spark plug.
	Spark plug connector contaminated?	Clean the spark plug connector.
	Spark plug contaminated?	Clean the spark plug
	Electrode clearance of spark plug incorrect?	Adjust gap to 0.7 mm to 0.8 mm
Motor does not start	Spark plug defective?	Replace spark plug
	Air filter contaminated?	Cleaning/replacing the air filter
Motor misfires when running	Spark plug connector not firmly attached?	Push the connector firmly onto the spark plug.
	Incorrect fuel?	Drain tank and fill up with the correct fuel
	Throttle at 	Return throttle to direction 
Motor does not reach the maximum speed.	Air filter contaminated?	Cleaning/replacing the air filter
	Spark plug contaminated?	Clean the spark plug
	Distance from electrode to spark plug too great?	Adjust gap to 0.7 mm to 0.8 mm
	Incorrect fuel?	Drain tank and fill up with the correct fuel
Drive is not working	Wrong tension of Bowden cable for the drive?	Have it checked by an expert.
	Drive defective?	Have it checked by an expert
Mowing drive is not working	Wrong tension of Bowden cable for the mowing drive?	Have it checked by an expert
	Mowing drive defective?	Have it checked by an expert
Strong vibrations	Loose or damaged parts?	Check the product for loose or damaged parts

If you cannot eliminate the error yourself, please contact Dealer's Service directly. Please be aware that any improper repairs will also invalidate the warranty and additional costs may be incurred.

Usable fuels and lubricants

 **DANGER! Danger of fire!**

Avoid damage caused by leaking fuel: Drain the tank before disposing of the product.

 **CAUTION! Environmental damage!**

Damage caused by leaking operating media: Remove operating media before disposing of the product.

- Normal petrol, unleaded, recommend gasoline grade 90# over.
- Motor oil: SAE 15W-40 or 10W-30
- Gearbox oil: L-CKE-/P-320

17. DECLARATION OF CONFORMITY



BUILDER SAS

32 rue Aristide Bergès - Z.I. du Casque - 31270 Cugnaux - France

Tel: +33 (0) 5.34.508.508 Fax: +33 (0) 5.34.508.509

Declare that the machine designated below

PETROL REAPER

HFT200-1

S/N: 20231107532-20231107619

Conforms to the provisions of the Machinery Directive 2006/42 / EC and the national regulations transposing it;

Also complies with the provisions of the following European directives:

To the EMC Directive 2014/30 / EU

Emission directive (EU) 2016/1628 & 2017/656/EU

Directive 2000/14 / EC Annex VI, 2005/88 / EC

Also complies with European standards, national standards and the following technical provisions:

EN 12733: 2018

EN ISO 12100: 2010

EN ISO 14982: 2009

Sound pressure level $L_{pA} = 90.4\text{dB (A) K} = 3\text{dB (A)}$

Sound power level $L_{wA} = 105.4\text{dB (A) K} = 3\text{dB (A)}$

Guarantee sound power level $L_{wA} = 108\text{dB (A)}$

Cugnaux, 11/10/2023

Philippe MARIE / CEO

Technical file manager: Julia Zou

18. WARRANTY

HYUNDAI

WARRANTY

The manufacturer guarantees the product against defects in material and workmanship for a period of 2 years from the date of the original purchase. The warranty only applies if the product is for household use. The warranty does not cover breakdowns due to normal wear and tear.

The manufacturer agrees to replace parts identified as defective by the designated distributor. The manufacturer does not accept responsibility for the replacement of the machine, in whole or in part, and/or ensuing damage.

The warranty does not cover breakdowns due to:

- insufficient maintenance.
- abnormal assembly, adjustment or operations of the product.
- parts subject to normal wear and tear.

The warranty does not extend to:

- shipping and packaging costs.
- using the tool for a purpose other than that for which it was designed.
- the use and maintenance of the machine done in a manner not described in the user manual.

Due to our policy of continuous product improvement, we reserve the right to alter or change specifications without notice. Consequently, the product may be different from the information contained therein, but a modification will be undertaken without notice if it is recognized as an improvement of the preceding characteristic.

READ THE MANUAL CAREFULLY BEFORE USING THE MACHINE.

When ordering spare parts, please indicate the part number or code, you can find this in the spare parts list in this manual. Keep the purchase receipt; without it, the warranty is invalid. To help you with your product, we invite you to contact us by phone or via our website:

- **+33 (0)9.70.75.30.30**
- **<https://services.swap-europe.com/contact>**

You must create a "ticket" via the web platform.

- Register or create your account.
- Indicate the reference of the tool.
- Choose the subject of your request.
- Describe your problem.
- Attach these files: invoice or sales receipt, photo of the identification plate (serial number), photo of the part you need (for example: pins on the transformer plug which are broken).



19. PRODUCT FAILURE

WHAT TO DO IF MY MACHINE BREAKS DOWN?

If you bought your product in a store:

- a) Empty the fuel tank if your product has one.
- b) Make sure that your machine is complete with all accessories supplied, and clean! If this is not the case, the repairer will refuse the machine.

Go to the store with the complete machine and with the receipt or invoice.

If you bought your product on a website:

- a) Empty the fuel tank if your product has one..
- b) Make sure that your machine is complete with all accessories supplied, and clean! If this is not the case, the repairer will refuse the machine.
- c) Create a SWAP-Europe service ticket on the site: <https://services.swap-europe.com> When making the request on SWAP-Europe, you must attach the invoice and the photo of the nameplate (serial number).
- d) Contact the repair station to make sure it is available before dropping off the machine.

Go to the repair station with the complete machine packed, accompanied by the purchase invoice and the station support sheet downloadable after the service request is completed on the SWAP-Europe site

For machines with engine failure from manufacturers BRIGGS & STRATTON, HONDA and RATO, please refer to the following instructions.

Repairs will be done by approved engine manufacturers of these manufacturers, see their site:

- <http://www.briggsandstratton.com/eu/fr>
- <http://www.honda-engines-eu.com/fr/service-network-page;jsessionid=5EE8456CF39CD572AA2AEEDFD290CDAE>
- <https://www.rato-europe.com/it/service-network>

Please keep your original packaging to allow for after-sales service returns or pack your machine with a similar cardboard box of the same dimensions.

For any question concerning our after-sales service you can make a request on our website <https://services.swap-europe.com>

Our hotline remains available at +33 (9) 70 75 30 30.



20. WARRANTY EXCLUSIONS

THE WARRANTY DOES NOT COVER:

- Start-up and setting up of the product.
- Damage resulting from normal wear and tear of the product.
- Damage resulting from improper use of the product.
- Damage resulting from assembly or start-up not in accordance with the user manual.
- Breakdowns related to carburetion beyond 90 days and fouling of carburetors.
- Periodic and standard maintenance events.
- Actions of modification and dismantling that directly void the warranty.
- Products whose original authentication marking (brand, serial number) has been degraded, altered or withdrawn.
- Replacement of consumables.
- The use of non-original parts.
- Breakage of parts following impacts or projections.
- Accessories breakdowns.
- Defects and their consequences linked to any external cause.
- Loss of components and loss due to insufficient screwing.
- Cutting components and any damage related to the loosening of parts.
- Overload or overheating.
- Poor power supply quality: faulty voltage, voltage error, etc.
- Damages resulting from the deprivation of enjoyment of the product during the time necessary for repairs and more generally the costs related to the immobilization of the product.
- The costs of a second opinion established by a third party following an estimate by a SWAP-Europe repair station
- The use of a product which would show a defect or a breakage which was not the subject of an immediate report and/or repair with the services of SWAP-Europe.
- Deterioration linked to transport and storage*.
- Launchers beyond 90 days.
- Oil, petrol, grease.
- Damages related to the use of non-compliant fuels or lubricants.

* In accordance with transport legislation, damage related to transport must be declared to carriers within 48 hours maximum after observation by registered letter with acknowledgement of receipt.

This document is a supplement to your notice, a non-exhaustive list.

Attention: all orders must be checked in the presence of the delivery person. In case of refusal by the delivery person, it you must simply refuse the delivery and notify your refusal.

Reminder: the reserves do not exclude the notification by registered letter with acknowledgement within 72 hours.

Information: Thermal devices must be wintered each season (service available on the SWAP-Europe site). Batteries must be charged before being stored.

HYUNDAI

POWER PRODUCTS



For inquiries, please contact:

BUILDER SAS

32 rue Aristide Bergès - Z.I. du Casque - 31270 Cugnaux - France

Tél.: +33(0)5.34.502.502 Fax.: +33(0)5.34.502.503

<http://www.hyundaipower-fr.com/>

Fabriqué en République Populaire de Chine(PRC)